

Installation and operating manual

Refrigerators, freezers and wine storage appliances



Rev 082023



FESTIVO

Table of contents

Table of contents	3
Intended use	4
Models	4
Acceptance	4
Before using the appliance	4
Precautions	5
Installation	6
Operation principle of the appliance	14
Switches and thermostats: refrigerator and freezer	14
Switches and thermostats: wine storage appliance	15
Switching on	15
Switching off	16
Temperature adjustment: refrigerator and freezer	16
Button lock and unlock	17
Freezing	17
Temperature adjustment: wine storage appliance	17
Normal sounds of the appliance	19
Automatic defrosting	19
Storing goods	20
Cleaning	24
User maintenance	28
Malfunctions and repairing small faults	29
Error messages	30
Service	31
Warranty conditions	32
Decommissioning the appliance	32
Notes	33



Intended use

Festivo refrigeration appliances are suited to refrigerating and freezing food. The appliances are intended for domestic use. For institutional use, regulations concerning the sector should be considered.

Festivo refrigeration appliances have been designed and tested in accordance with the rules and regulations in force.

Festivo refrigeration appliances can be serviced only by an authorized service center. Repairs by unqualified persons can endanger the user of the appliance or the environment.



Models

Appliance models in the operating instructions are: refrigerator, freezer, refrigerator freezer, and wine storage appliance. The refrigerator comes with a FRUIT AND VEGETABLE drawer, and the freezer has a ZERO drawer as standard equipment.

Note!

The equipment and accessories in the instruction manual pictures are not necessarily standard equipment of the appliance(s).



Refrigerator CM



Freezer FM



Refrigerator freezer CFM
(consists of separate appliances)



Wine storage appliance
VLM

Acceptance

Check the appliance before accepting it. In case you detect damages in transit to the appliance please note it down into the transport document, and inform the shipment company and seller immediately.

Note!

The manufacturer's warranty does not cover damages in transit!

Before using the appliance

Read the installation and operating manual carefully. It includes important information about the installation, use and maintenance of the appliance.

Do not start to use the appliance immediately after transportation or after it has been kept in a cold place, but let it stand in its final location for a few hours so that the oil has time to flow down into the compressor.

Precautions

The appliance must be attached to the wall (A) on the top of the cabinet or prevent the appliance of falling over in another manner. If the angle plate does not reach the wall use a suitable connecting piece for it. The wall mounting screw and plug Ø 6 mm (B) are taped to the inside of the device.

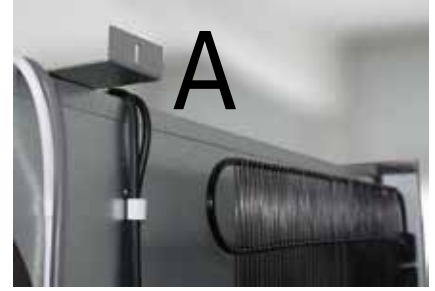

Before cleaning, turn off the appliance from the power switch and unplug it from the socket.

Leave the doors open when the appliance is not in use.

Alcoholic substances and conserves containing alcohol e.g. gherkins, pickled beetroot and lingonberry puree must be stored upright in a tightly sealed container.

Do not store opened sparkling wine bottles in the door locker, because of the movement of opening the door can loosen the bottle cork with a lot of pressure and it can cause damage with its trajectory.

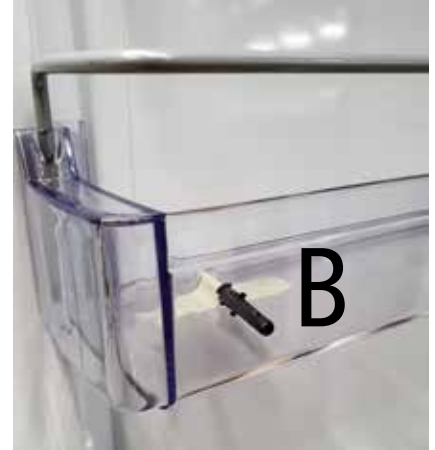

Do not store glass bottles with freezing liquids in the freezer. The bottle can break. Do not store explosive substances in the refrigerator freezer.

Warning!

It is not allowed to install the appliance in a space that is too small because of possible leakage of refrigerant forming an explosive mixture of gas. The room size should be at least 8 m².

The appliance contains a small amount of environmentally friendly but flammable refrigerant R600, which does not damage the ozone layer or cause greenhouse effect. Check the refrigerant piping for damages in transit or during installation. Leaking refrigerant can injure eyes or ignite.



When noticing a refrigerant leakage:

- do not let open fire into the room
- turn off power to the appliance from the main switch
- unplug the appliance from the socket
- air the room for several minutes
- contact the Festivo service center

Note!

Keep the air circulation vents free of obstacles both up and down.

Do not use mechanical tools to speed up melting the ice or other than recommended methods by the manufacturer.

Do not damage the refrigerant piping.

Do not use any electrical equipment inside the refrigerator freezer unless it is recommended by the manufacturer.

The refrigerator freezer must be fastened to a wall following instructions on page 4.

Installation

PLACEMENT

The intended environmental temperature classification has been indicated on the appliance nameplate. The nameplate is situated on the right inner wall of the refrigerator.

SN	+10 ... +32 °C
N	+16 ... +32 °C
ST	+18 ... +32 °C
T	+18 ... +43 °C



Place the appliance in a dry and well ventilated room with a size of at least 8 m².

Do not place the appliance in the immediate proximity of a radiator, stove, or an other heat source.

Proper functioning of the refrigerator engine requires a good air circulation. The air circulation vent at the front of the appliance should not be covered.

Note!

Manufacturer's warranty does not cover damages that are caused by faulty installation. Check that the cooling air circulation meets at least the instruction requirement.

The placement floor must be even, horizontal, and at the same level with the finished floor.

Frost, that is formed in the refrigerator evaporator, will be defrosted automatically by the appliance. Melt water is lead to an evaporation dish in the compressor space. Water evaporates from the evaporation vessel automatically. In the case of a malfunction of the unit some water can be spilled onto the floor.

Note!

Always place a safety container under the unit.

If the refrigeration assembly includes several appliance modules, install a module wide safety container under each unit. The picture shows an example of a 120 CFM refrigerator freezer safety container assembly. The safety container is available as additional equipment.

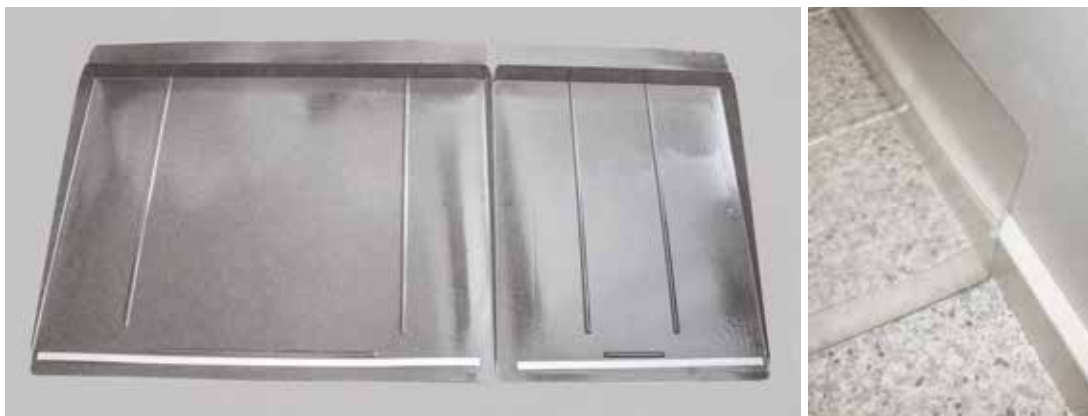

Alternatively, the location of the refrigerator freezer can be made watertight in other ways. A watertight base will be raised up onto the wall so that the possible leakage water cannot enter the structure via the floor or wall joints.

Check that the plastic evaporation basin on top of the compressor is properly in place. Move the dish to its position if it has been misplaced in transit.

Other furniture should not be fastened to the refrigerator freezer. One should be able to pull it out for cleaning and maintenance.



INSTALLATION DISTANCES FROM OTHER DEVICES AND SURFACES

Note!

For more detailed installation dimensions and methods, see a separate installation manual that can be downloaded address www.festivo.fi the product information of the device in question.

The refrigerator freezer can be placed touching the surfaces on the back and sides. In case the Festivo appliance's side surface is next to another cooling unit or outer wall, a ventilation gap of 10 mm width should be left in between the surfaces.

If the appliance is installed next to a wall it should be off the wall with at least 35 mm gap, so that the door opens sufficiently and the drawers can slide freely out from inside the cabinet.

When opening, the door corner crosses the outside line of the device. If the front surface of the door of the appliance is on the same level as the outer surface of the cabinet, leave a minimum gap of 5 mm between the hinge side of the appliance and the cabinet.

If a full deep upper cabinet is installed above the appliance, at least 40 mm of empty air circulation shall be left between the appliance and the upper cabinet (1). If the top cabinet is immediately above the appliance, at least 80 mm of empty space shall be left behind and above the cabinet (2). There must be at least 80 mm of empty space between the freestanding device and the ceiling of the room (3).

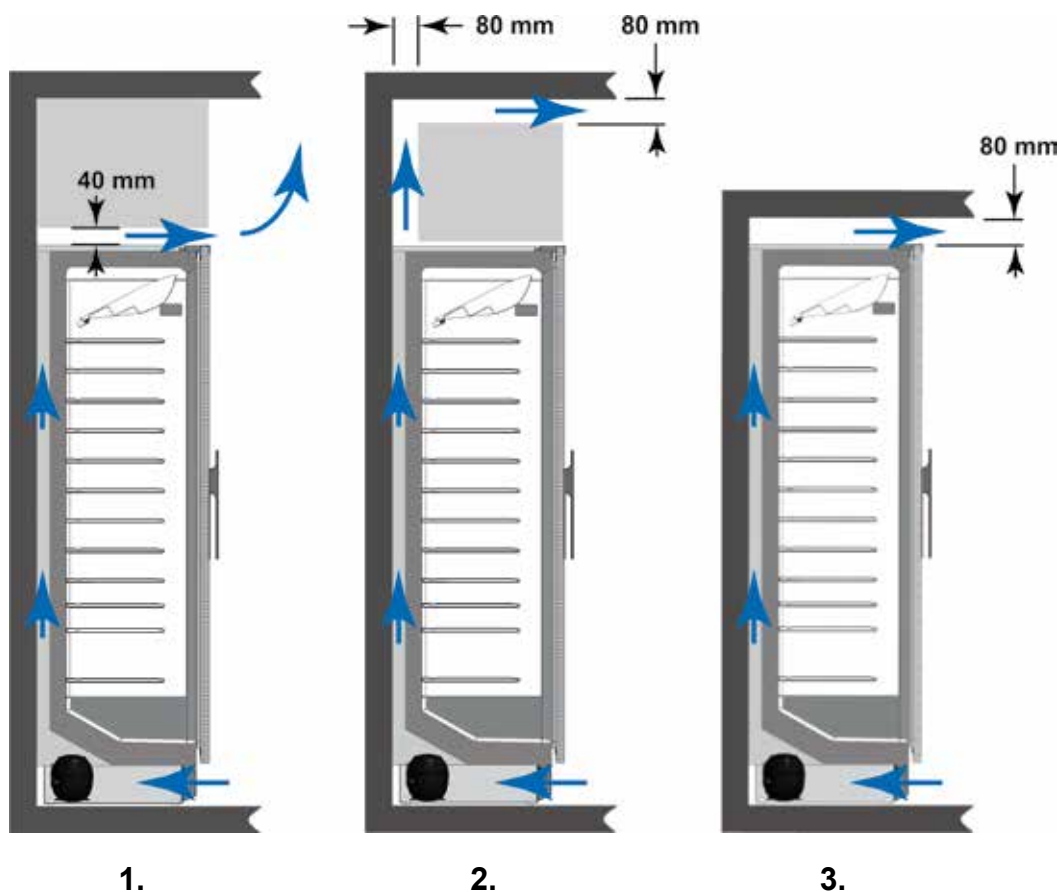

ELECTRICAL CONNECTIONS

Connect the refrigerator and freezer power cords and both refrigerator freezer power cords to a single phase 230 V 50 Hz socket. The socket fuse size is 10 A.

Only a electrician is allowed to make changes to the plugs change the power cord.

A suitable socket is a socket on the back surface at a height of 2060 mm measured from the floor surface until the bottom edge of the socket. The socket can be in the ceiling at similar height and at a maximum of 500 mm from the back wall.

The socket must be positioned in such a way that it is possible to pull the appliance's plug from the socket without having to move it.

The extra power cord cannot be pushed behind the furniture into the condenser space but it has to be left on top of the refrigerator freezer.

Due to danger of overheating the appliance should not be connected to the power grid by means of a branch outlet or an extension cord.

BALANCING AND LOCKING THE WHEELS: REFRIGERATOR, FREEZER AND WINE STORAGE APPLIANCE 45 VLM

Please check that the wheel locking screws C of are open.

Push the appliance to its place. Install it to the same level as the rest of the floor surface.

Straighten the appliance with the adjusting screws A (2 pcs) and tighten the locking screws C. The work requires a 10 mm spanner.

If the appliance tilts towards the back even if the adjusting screws A have been completely loosened it's necessary to place sheet material under the back wheels to heighten the back edge.

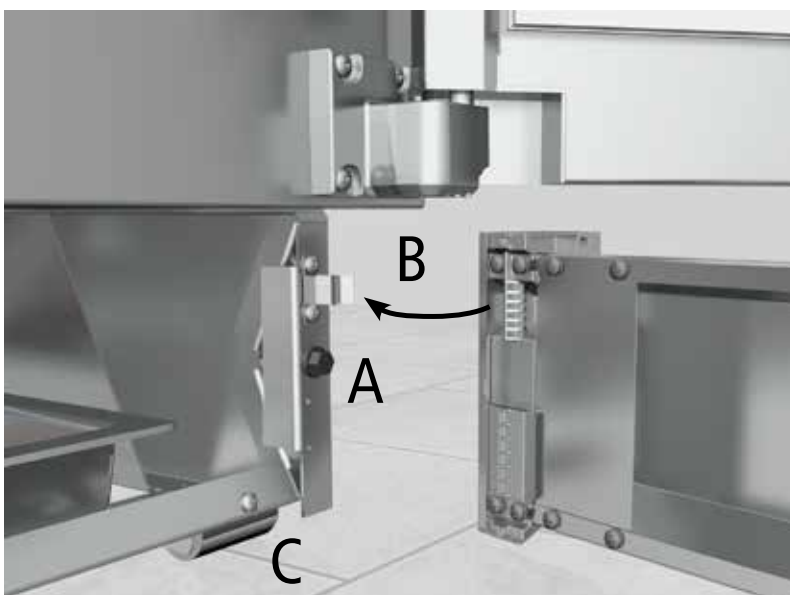

120 cm wide appliances:

Turn the adjusting foot in the middle in such a way that it touches the floor.

INSTALLING FRONT PANEL OF THE PLINTH

Mount the front panel of the plinth to its place. The front panel is attached to the plinth with two fasteners B (2 pcs). When you have pressed the front panel in its place, lift it upwards as far as it lifts.

FALL PREVENTION

Fasten the furniture to the wall with the angle plate on top of the cabinet and prevent otherwise the appliance from falling over by accident.



CONNECTING APPLIANCE COMBINATIONS OF 100 CFM AND 120 CFM TO EACH OTHER

EXTENSION ACCESSORY PACKAGE INCLUDES:
(additional equipment to individually sold
modules of 55 CM, 75 CM, 45 FM and 45 VLM)

1. Aluminum profile for in between the frames
2. Support strips for the top
3. Ceiling fastener
4. Plinth fasteners
5. Screws 4.2 and M6

Unpack the packages next to mounting location.
Adjust the appliances to a horizontal position (see
chapter 'Balancing and locking the wheels') and
fasten them to each other.

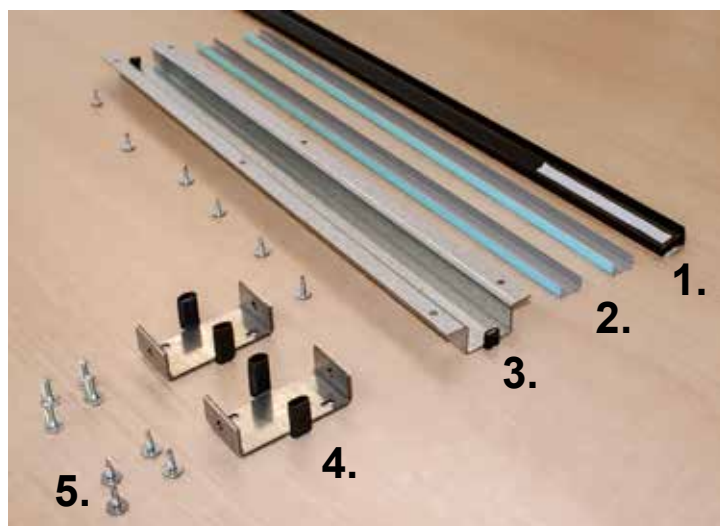

The frames will be attached to each other from the top (2, 3), front plinth (4)
and back plinth (4). An aluminum profile cover will be installed in between the
appliances (1).

BACK PLINTH FASTENER (4)

Mount the plinth fastener to the lower edge of the plinth. Fasten the 4.2 drill
screws to the holes on the back edge and tighten the joint from both sides
evenly with M6 screws.



CEILING FASTENER (3) AND FRONT EDGE ALUMINIUM PROFILE FOR INBETWEEN THE FRAMES (1)

First install the support lists (2) on the
roof of the appliance under the top
lids and press the ceiling fastener (3)
against the ceiling.

Push the appliance to its place. Check
that the front surfaces of the frame
are on the same level.

Remove the protective tapes (1b) of
the sealing band on the aluminium
profile and first press
the top of the profile into place (1).

Finally, press the aluminium profile
tightly along its entire length against the front surface of the frame.

Fasten the ceiling fastener (3) 4.2 with screws (6 pcs) to the
mounting holes.

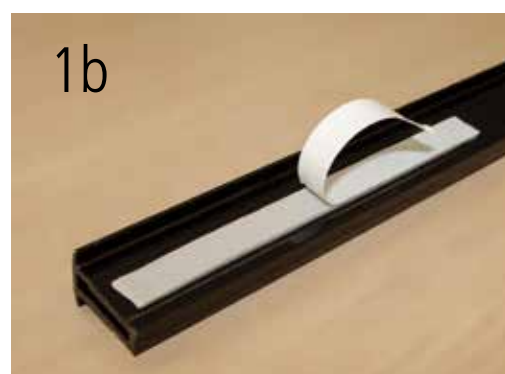

BALANCING AND LOCKING THE WHEELS

Adjust the appliances to the same level with adjustment screws A and fasten the wheel locking screws C. The work requires a 10 mm spanner.

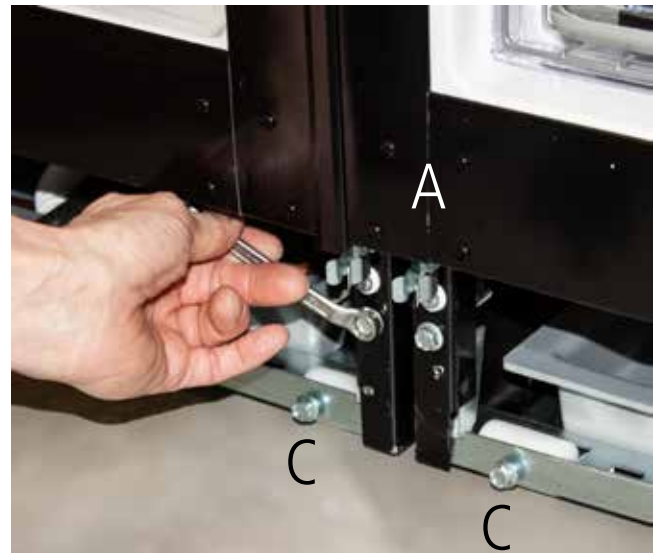

FRONT PLINTH FASTENER (4)

Mount the plinth fastener to the lower edge of the plinth. Fasten the 4.2 screws (a) to the holes on the front edge and tighten the joint from both sides evenly with M6 screws (b).

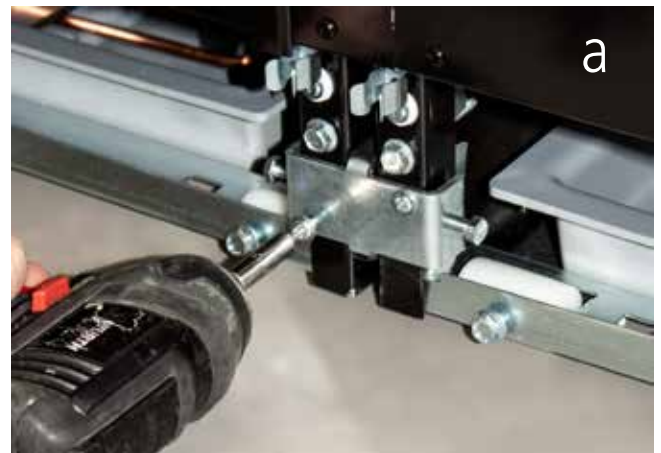

Mount the front panel of the plinth to its place.



MOUNTING SHELVES (DOUBLE DOOR REFRIGERATOR MODELS 90, 100 AND 120 CM)

Adjust shelf brackets to desired height.

Slide the flanges of the back side bracket (A) to the pin slots at the back of the cabinet.



Shelf bracket

Lower flanges of the front side bracket (B) to the pin slots at the middle of the cabinet.

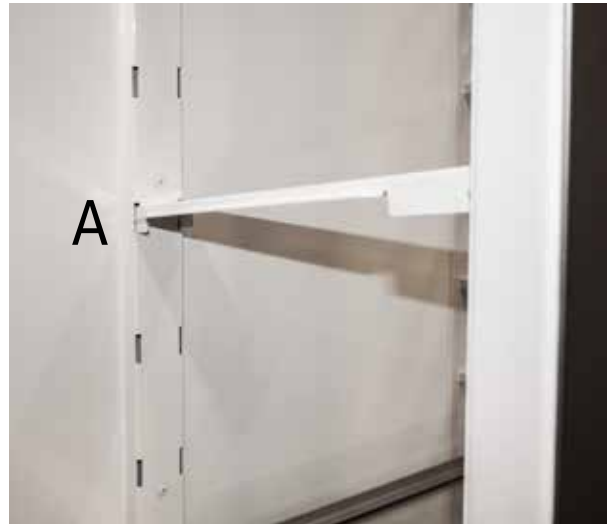

Place the shelf at its place. Make sure that both ends of the shelf are on top of the bracket.



MOUNTING SHELVES



DOOR ADJUSTMENT: REFRIGERATOR, FREEZER, AND WINE STORAGE APPLIANCE 45 VLM

During the initial installation of a new device, there is usually no need to adjust the doors, because the doors are adjusted at the factory. If the doors need to be adjusted when connecting the devices, it may be due to the unevenness of the floor. Small unevenness in the floor can be corrected with the adjustment screws on the base of the device.

Check the position of the door in relation to the frame. If the door is not straight, it can be adjusted with hinges.

Lateral adjustment, picture 1

Loosen top hinge screws. Turn the hinge sideways (arrows C) until the door is straight and tighten the screws.

The measurement A (picture 3) has to be the same on the top and bottom of the door. If it is not the same, move the upper hinge (arrows B) so that the measurement A is the same both up and down. Tighten the screws.

Bottom hinge, picture 2

Bottom hinge can only be adjusted sideways.

Please check how well the seal fits to the frame. If the seal is too compressed on the hinge side, move the hinge outward.

If the hinge is compressed and it does not touch the casing, heat it CAREFULLY with a hairdryer and make the seal higher by molding it by hand.

If the hinges are in the middle of the appliance the protective case on the top has to be unmounted first so that the top hinge can be adjusted.

Varoitus!

Turn off the power and unplug the power cord from the socket before underheating the protective case.

Grease the hinges if necessary.

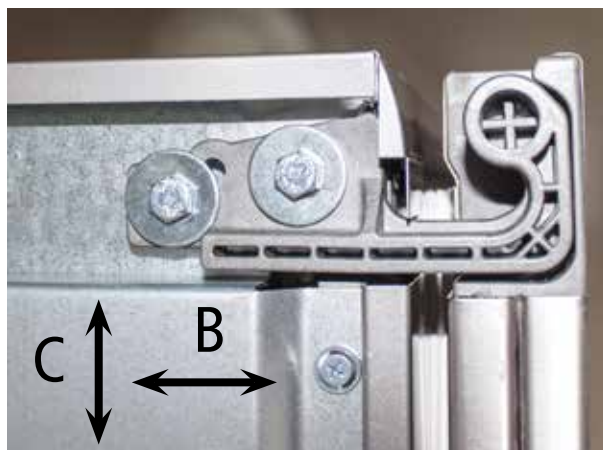

Top hinge, picture 1

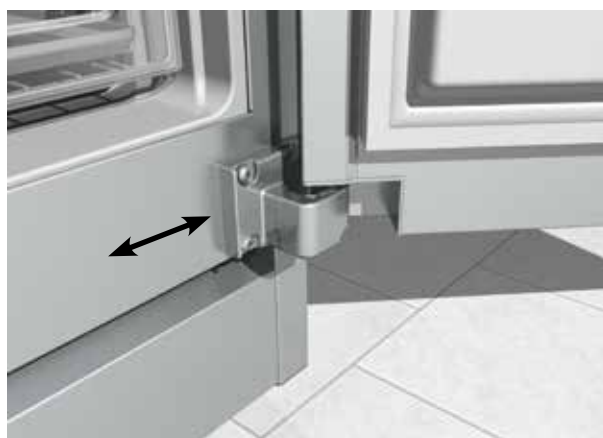

Bottom hinge, picture 2



Picture 3

Operation principle of the appliance

The cooling system, consisting of a compressor, a condenser and an evaporator, operate as a closed circuit, where the compressor circulates the refrigerant.

In the evaporator the refrigerant vaporizes and absorbs heat, cooling the refrigerator and the freezer.

The heat, bound to the refrigerant, is transferred into the surrounding air via the condenser.

Any ice formed in the evaporator melts automatically and melt water will be lead into an evaporation dish in the compressor space, where it will evaporate automatically.

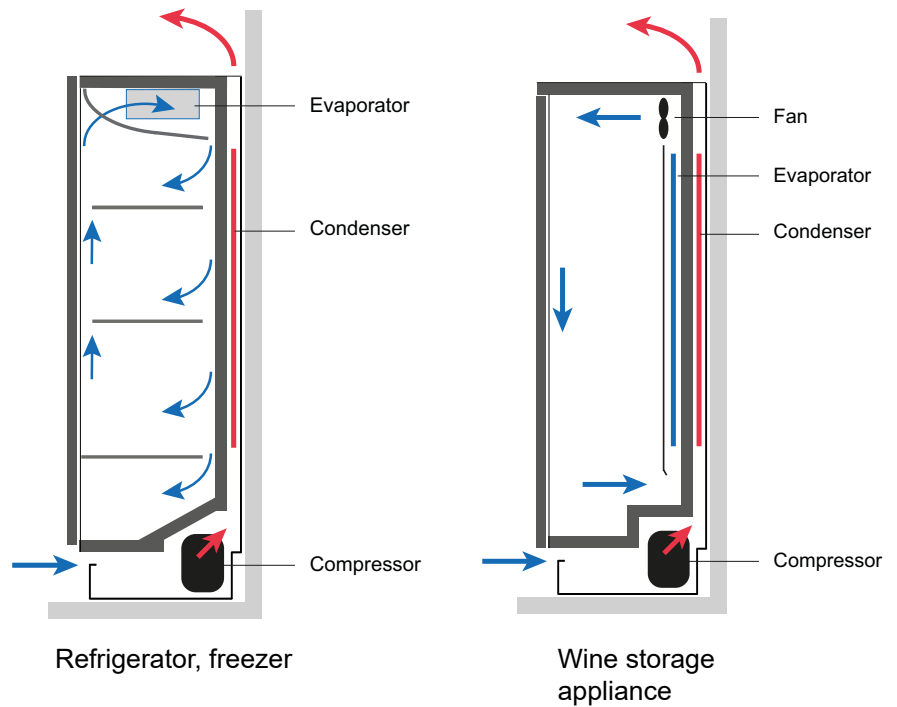

Switches and thermostats: refrigerator and freezer

The refrigerator CM and freezer FM have one temperature controller. Freezer cabinet CFM has two temperature controllers; one for the refrigerator and the other for the freezer.



1. Main switch (switches the voltage for the appliance)
2. Temperature controller
3. Door switch

FM model ZERO drawer temperature has been adjusted at the factory to as close as possible to zero degrees Celsius. Temperature range is 0 ...+2 °C. The freezer has to be on for the ZERO drawer to cool.

Switches and thermostats: wine storage appliance



1. Main switch (switches the voltage for the appliance)
2. Light switch
3. Cabinet temperature controller

Switching on

Do not start to use the appliance immediately after transportation or after it has been kept in a cold place, but let it stand in its final location for a few hours so that the oil has time to flow down into the compressor.

Before using the appliance, clean its interior parts (see the chapter on "Cleaning"). Push the plug on the connecting lead of the appliance into the electric socket.

Do not place food into the appliance before the temperatures in the refrigerator and freezer have reached their set values.

At the factory, the main switch of the appliance (1) was left in the OFF position.



Refrigerator or freezer

1



Wine storage appliance

Push the main switch (1) and then within 10 seconds the temperature of the refrigerator will appear on the display.

Inside temperatures of the appliance can be monitored from the controller display.

Switching off



1

Switch off the appliance using the main switch (1)

The appliance compressor can be switched off separately. Press display power button  until the display switches off.

Temperature adjustment: refrigerator and freezer



FACTORY SET RECOMMENDED TEMPERATURE VALUES



- refrigerator +5 °C
- freezer -18 °C

Temperature set-point can be shown by pressing the display button  (refrigerator or freezer) in summary. The display shows the temperature set to the controller.

Temperature for refrigerator can be set to range +2 to +7 °C.

Temperature for the freezer can be set to range -16 to -24 °C.





CHANGING THE TEMPERATURE

Press the display  button approximately 3 seconds until the C-symbol begins to flash. Select the desired temperature with the arrow keys  and .

Arrow up raises the temperature and arrow down lowers it.

The display returns to show the interior temperature.

Button lock and unlock

- Press simultaneously buttons  and  at least for three seconds. The text 'PoF' will display when the keys are locked. If the keyboard is locked it is impossible to adjust the temperature or switch of the power of the unit.
- Press simultaneously buttons  and  at least for three seconds. The text 'Pon' will display when the keys are unlocked.

Freezing

Activate the freezing function six hours before putting goods into the freezer. This function is used when amounts of goods larger than 2 kg are being frozen (see the chapter on "Freezing"). After six hours the temperature returns to the set value without requiring any other action.

Setting the freezing:

Press the freezer's temperature arrow button for  approximately three seconds, until the freezing function starts. On the display appears an indicator light for freezing .

Temperature adjustment: wine storage appliance





CABINET TOP PART TEMPERATURE

Cabinet top part temperature has been set at the factory to +13 °C and the display will normally indicate the temperature at the top part.

You can CHECK top part set-point temperature by pressing the button  briefly.

You can CHANGE the top part temperature set-point in the range between +9...+18 °C. Press the button  until °C symbol starts flashing. Select the desired temperature with the arrow keys

 and . Arrow UP raises the temperature and arrow DOWN lowers it. The desired temperature saves automatically and no separate checking out is required. The display returns to show the cabinet top part temperature.

CABINET LOWER PART TEMPERATURE (ONLY VLM 45)



The temperature in the cabinet's lower part cannot be adjusted separately with the temperature controller but the temperature of the lower part will be adjusted by plastic adjustment sheets (A) under the shelf.

The adjustment sheets you can adjust the temperature difference between the top and lower parts at a maximum of approx. 5°C.

If the lower part temperature is too low you pull the adjustment sheet slightly outward. If the temperature is too high, the sheet will be pushed backward. The purpose of the adjustment sheet is to restrict or expand the air circulation in the wine storage appliance.

After adjusting the temperature, it needs to stabilize for approximately 24 h, where after the lower part temperature can be readjusted.

The temperature display of the appliance shows normally the temperature of the cabinet's top part.

Lower part temperature can be displayed by pressing simultaneously the buttons  and  for approximately 3 seconds until the text dP3 appears in the display. Then press the  button again and the wine storage appliance's lower part temperature will be displayed. The controller returns to normal after 15 seconds.

Note!

The air circulation inside is influenced by the wine storage appliance's filling level, which is at it's maximum 70 normal size wine bottles.

Recommended temperature:

- Top part, white wine +9...+14 °C
- Lower part, red wine +14...+18 °C



Normal sounds of the appliance

The appliance acquires its coldness from the compressor operated cooling system. The system makes sounds of varying levels and they can increase especially during the defrosting phase. The volume of the noise is also affected i.e. by the materials in the environment where it is placed (e.g. stone floors), the manner of positioning the appliance, the way it is used and its age.

Resonance noise may be produced if the appliance is not completely straight, or if parts of the pipe system are touching one another. The pipes can be bent apart carefully by hand.

It may be possible to hear noises generated by the thermal expansion of metal parts of different sizes, following the start or stopping of the operation of the unit.

COOLING SYSTEM

When the refrigerant flows through the pipelines one may hear hissing or bubbling noises. During the defrosting phase a cracking sound can be heard.

During the defrost cycle of the freezer, the sound of the refrigeration equipment is louder than normal and the defrost valve clicks at the beginning and end of the defrost cycle.

THERMOSTAT

The compressor is started and stopped by a thermostat. When the thermostat switches on, it makes a low cracking sound. The compressor is required to run more frequently if the doors are opened more often.

COMPRESSOR

When the refrigerant is being pumped, a droning or "snoring" noise is heard from the compressor motor and the pump.

INDOOR FAN (FREEZER AND WINE CABINET)

The fan of the device keeps a steady low hum.

FREEZER DEFROST VALVE

When connected, the defrost valve makes a sharp click.

Automatic defrosting

Both the refrigeration and the freezer have an automatic defrosting function, which can be switched on as required.

Refrigerator:



During defrosting the temperature of the refrigerator may temporarily rise by a couple of degrees. The temperature always returns to the set value when defrosting is complete.

Freezer:

In the freezer the temperature may temporarily rise during energy-efficient defrosting.



Defrosting can be activated manually if the temperature has begun to rise.

Press the manual defrost button  for a couple of seconds to activate defrosting. During defrosting the defrost indicator is shown  and the display shows DEF. Defrosting takes a couple of minutes. The temperature always returns to the set value when defrosting is complete.

Storing goods

COLD STORAGE (CM AND CFM MODELS)

The factory setting of the refrigerator inside temperature has been set to +5 °C. The temperature may vary by several degrees from the set value in different parts of the refrigerator. The relative air humidity in the cabinet is about 70-90%.

Note!

In damp weather, water may condense on the surface of the drip-water trough or on the inside wall. This may be remedied if the cabinet temperature is adjusted to be a few degrees colder.

Juices and preserves can also be stored in the cooling cabinet for long periods of time. Foodstuffs for day-to-day use will normally keep for a few days. Vegetables keep best in the vegetable drawer.



FRESH STORAGE IN NOLLA DRAWER (FM AND CFM MODELS)

The temperature of the NOLLA drawer continually stays close to 0 °C. The low temperature ensures that fresh foodstuffs will keep well. These foods are fresh meat, fish and leftovers. Foodstuffs that are sensitive to cold are not suitable for keeping in the fresh storage compartment. These include vegetables and fruit that contain a lot of water, e.g. potatoes, cucumber, marrow, pumpkin, bananas and tomatoes.

Note!

NOLLA drawer is meant for storing already cooled foods, not for cooling them down.



Adjustment of NOLLA box temperature:

Above the NOLLA box, at the rear edge of the intermediate bottom, is a control valve (A) that is closed (B) at the factory. When you move the valve control plate (C) to the left, the valve opens and the NOLLA box temperature drops. When you move the control plate to the right, the NOLLA box temperature rises.

Move the plate only slightly at a time and allow the NOLLA box temperature to equilibrate for about a day before re-adjusting.

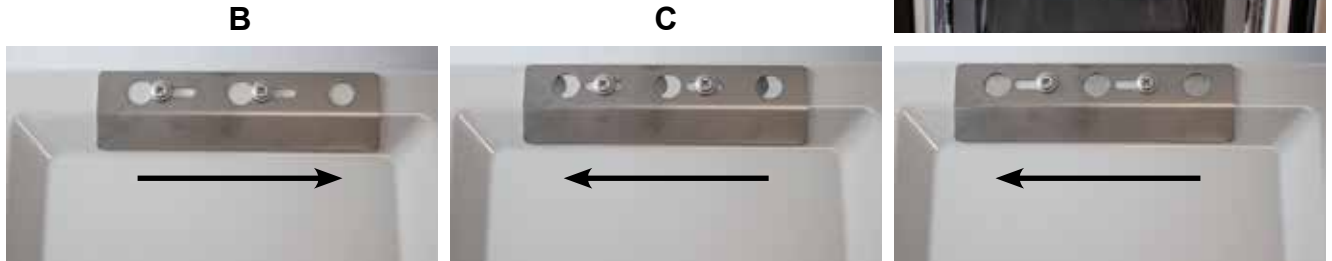

FROZEN FOOD STORAGE (FM AND CFM MODELS)

The quality of frozen foods deteriorates if the maximum storage period is exceeded. The storage period depends on the type of food.

PLACING FOOD INTO THE REFRIGERATOR FREEZER

Let hot foods and drinks cool down before placing them into the refrigerator

Note!

Hot products cannot be frozen but they need to be pre-cooled in the refrigerator before freezing.

Package or cover the foods if possible. When packaged the food taste, humidity and freshness will keep the best and other foods will not take on other tastes.

Vegetables, fruit and salads can be stored in the vegetable drawer without packaging.

Note!

Do not push foods against the back wall but leave a gap for air circulation between the back and side walls.

Food is best to place according to the temperature distribution in the refrigerator. In that way you ensure the best possible storage temperature for foods.



Door lockers:

Door lockers are best suited for storing products that are light and used daily. Keeping heavy products in the door lockers will strain the hinges.

Refrigerator:

Temperature can be adjusted to +2 ... +7°C. The temperature set in the refrigerator thermostat is the average temperature of the cabinet. The refrigerator's natural air circulation enables storage of different products in temperatures best suited for each. The products requiring coldest temperatures should be kept in the upper part of the refrigerator and products to be kept in cool temperatures in the lower part of the refrigerator.

Freezer:

Temperature can be adjusted between -16 ... -24°C. Drawer baskets should not be removed. Missing drawer basket will influence functioning of the appliance and evenness of temperature distribution.

HEVI drawer:

Temperature +8°C ... +12°C. The FRUIT AND VEGETABLE drawer is best suited for storing e.g. cucumber, tomato and pumpkin. Note! Not for storing potatoes.

NOLLA drawer:

The temperature is continuously near 0°C (0...+2°C). The fresh food storage compartment is best suited for storing meat, meat products, fresh fish and leftovers. These products keep considerably longer in this compartment than in the refrigerator. Note. Not for storing potatoes.

KIRA (additional equipment):

KIRA container series are meant for storing small foods in the refrigerator.

KAPPA (additional equipment):

KAPPA root vegetable container made from ash wood is meant primarily for storing root vegetables.



FREEZING



Note!

Before the freezing process is started, the foods already in the freezer are cooled down further to prevent them warming up too much, due to the effect of the products being frozen.

The freezer may be set to operate in freezing mode for six hours. The function is used when over 2kg of goods are frozen. Switch the freezer to positive drive six hours before starting the freezing.

Activating the function:



Always press the arrow button  on the freezer for at least three seconds until freezer indicator light  appears.

If the quantity to be frozen is the same as that stated as the freezing efficiency per day (max. 18kg at a time), then allow the engine to run for one extra 6-hour freezing period before freezing. After the 6-hour freezing cycle, the electronic thermostat automatically returns to the storage temperature.

Freezing goods temporarily rises the temperature inside the freezer, which may trigger the temperature alarm. In the display appear a text 'HA' and alarm indicator light . This is not a fault in the appliance and it will disappear as the freezing continues.

Leave a gap for air circulation between the products that are to be frozen; in this way, the products will freeze more efficiently.

Freezing time depends on the amount of goods that are to be frozen and other use of the freezer. In practice, the freezing time is approx. 0.5 – 1 day.

Cleaning

REFRIGERATOR AND WINE STORAGE APPLIANCE CLEANING

Clean inside the refrigerator and wine storage parts at least once a year. Clean also the condenser at the back.



Switch off refrigerator engine for the cleaning of inside surfaces.

Press display power switch . In the display appears a text 'OFF' and the machine turns off.

The interior should be cleaned approximately once a month. Do not let cleaning water enter control devices or lighting. You can clean all interior surfaces, excluding the door seal, with warm water, adding a little dish washing detergent. Abrasive or dissolving agents are not suitable for cleaning. Clean the door seal with water only. Dry the interior and the seal carefully.

Clean the evaporator pan once a year. Detach the pan by opening the screws (2 pcs.), allowing the pan to be lowered.



Start the refrigerator engine after cleaning. Press the button . The engine switches on and the display shows the temperature inside the refrigerator. The engine runs until the inside temperature has reached its inside set-point.



FREEZER CLEANING

Defrost and clean inside the freezer parts at least once a year. Clean also the condenser at the back.

Cool down the frozen goods in the freezer by setting a forced engine run time (6 hours). Press the arrow button



on the freezer for three seconds until freezing indicator light  displays.



Stop the freezer engine by freezer control power switch . In the display appears a text 'OFF' and the engine turns off.

Take the frozen goods from the freezer with the baskets and remove all goods from the ZERO drawer. Move the goods to the refrigerator, or outside in the winter time. To remove the freezer basket, first pull it to its outer position, then lift the front edge upward, and pull the basket out.

Leave the freezer door 1 cm open.

You can place for example a towel onto the bottom of the freezer to absorb any water dripping down the walls.

Cover the floor from possible splashing water. Wait until all the ice has melted.

It is recommended that the device is allowed to thaw and dry with the door open for at least 24 hours, so that all moisture formed in the air ducts has dried.

Clean and dry the interior surfaces of the freezer and ZERO drawer carefully and start the freezer again.

Leave the doors and drawers open when the appliance is not in use.

Warning!

It's not allowed to use e.g. a knife or hot air blower to remove the ice.

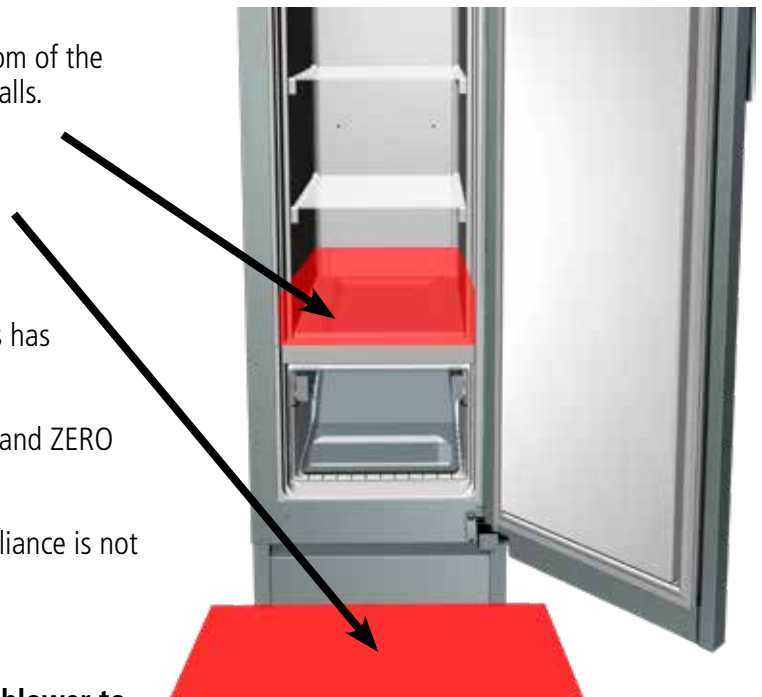

DOOR LOCKER AND DRAWER REMOVAL AND CLEANING

The door lockers can be removed for cleaning by lifting them upwards, causing it to detach.

The door compartments can withstand machine washing.



You can remove the HEVI, KYLMÄ and NOLLA drawers for cleaning. First pull out the drawer completely.

Remove the covering plugs A carefully with a chisel like object (e.g. cutlery knife) from both edges. Be careful not to scratch the drawer surface.

Unscrew the screws B from both holes and pull out the drawer from its rails.

The drawer can be wiped down with a damp cloth and a dishwashing liquid. Dry the drawer with care.

When you place the drawer back on its rails, please check that the rail hooks slide into the slots C at the back.

Fasten the screws and covering plugs back into their place.

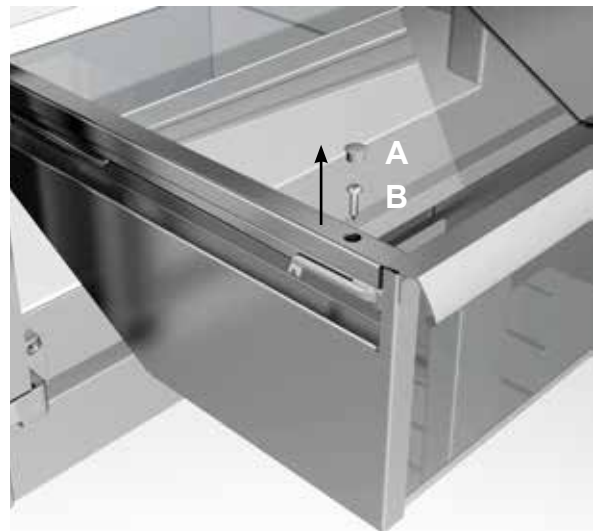

At the bottom of the NOLLA drawer there is a safety container D that can be removed for cleaning.

Pull the drawer out completely and remove the container through the opening at the back of the drawer.

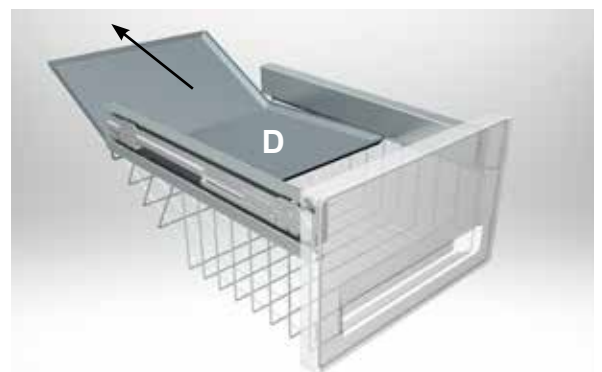

REMOVAL OF INSERT TRAYS (55 CM, 75 CM)

You can remove the bottom insert trays in the 55 CM and 75 CM refrigerators when cleaning.

Lift the insert trays upwards from the back edge.

Pull the shelves out carefully.

Warning!

Do not pull the shelves from the front edge because the back edge can distort.



User maintenance

Note!

Empty out the cooling appliance, switch it off from the power switch and unplug it from the socket during cleaning and other maintenance operations. Appliance combinations have separate power switches and plugs.

ENGINE CLEANING

Remove the front panel of the plinth and open the wheel locks.

Remove the wall angle plate and pull the appliance combination out to allow space to work behind it.

Vacuum the condenser, back surfaces and engine base from dust with a soft brush nozzle. Dirt in the compressor section and on the condenser impairs the unit's functioning and increase power consumption.

When vacuuming the condenser and mechanism, clean any loose dirt that may have accumulated inside the evaporation basin (A) with a toothbrush, for example. At the same time, check that the pool is intact and firmly in place, and that there are no cracks or other damages. Also check that the end of the condensate pipe is not blocked. Remove the screw (B) of the water lock and clean the water lock and, if necessary, the end of the condensate pipe from the inside. Screw the water lock back into place.

Push the appliance back into its place and check that all wheels are touching the floor and that the appliance is vertical.

Lock the wheel locks and fasten the angle plate screws and put the plinth back in its place. Grease the door hinges and adjust the doors if necessary.

Plug the power cord to the socket and switch on the cooling appliance from the power switch but fill it up only after it has reached its set storage temperature.



Warning!

The stainless steel doors and drawers have been treated with an Easy Clean coating, which protects surfaces from staining. Do not clean the surfaces with stainless steel cleaning product because it will damage the protective coating.

Malfunctions and repairing small faults

All malfunctions do not necessarily need to be solved with the help of a technician. Check first if, you can remove the malfunction with the help of the following instructions. If the appliance does not have a fault you will have to cover the cost of the service call even during the warranty period.

If the refrigerator engine does function, check the following:

- you have followed the operating manual instructions
- the plug is plugged properly into the socket
- the fuse is intact
- the main switch and power switches are in the 'on' position
- there are no disturbances in the power distribution

Note!

If the environment temperature becomes unusually high the compressor safety device can stop the engine. Restarting can take ½ - 1 h depending on the circumstances.

If the cooling capacity is poor:

- check that the doors and drawers are closed tightly.
- the doors have been opened often and kept open for too long
- too many products have been placed to cool at the same time
- air circulation is blocked either outside or inside
- check that the evaporators haven't gathered thick ice on them

Note! Thick ice in the refrigerator evaporator should be defrosted by switching off the refrigerator engine until the ice has completely melted. When defrosting large amounts it should be ensured that the evaporator dishes at the appliance base will not overflow onto the floor.

Refrigerator inside light:

The refrigerator has a long life led lighting. In the event of a failure please contact Festivo service.

The freezer notifies of excess heat (HA). Check first if:

- The freezer has been filled with too many products to freeze without freezer function

Freezing goods temporarily rises the temperature inside the freezer, which may trigger the temperature alarm. This is not a fault in the appliance and the alarm will disappear as the freezing continues.

- Freezer door has been left open. Switch on the automatic defrosting function (twice consecutively if necessary). If the appliance capacity remains low even after this and the temperature is still high after 24 h of defrosting, defrost the the freezer manually (see 'freezer cleaning'). If the above mentioned actions do not help please contact Festivo service.

Error messages

ERROR MESSAGES

Note!

You can silence the alarm sound by pressing any button.

P1 and P2 = sensor fault

The appliance works with the set program despite a sensor failure. However, the temperature can sometimes vary. The fault must be repaired. Please contact Festivo service

HA = high temperature alarm

Please see first chapter 'Malfunctions'. Please contact the Festivo service in case the above mentioned points are in good order and the appliance does not begin to cool within two hours.

LA = low temperature alarm

Please see first chapter 'Malfunctions'. Please contact the Festivo service in case the above mentioned points are in good order and the appliance does not begin to cool within two hours.



Service

If you can't remove the appliance malfunction, call the help of a technician. Do not try to repair the appliance by yourself, especially not its electrical parts.

Unnecessary opening of the doors will raise the temperature inside the refrigerator.

Warranty repairs can be done only by a service centers that are authorized by the factory.

Note!

When you order a warranty repair for the appliance please provide the unit warranty information:

- serial number and exact type number of the appliance. This information can be found on the name plate inside the refrigerator, on the right side.
- Appliance purchase and delivery date.

Note!

The warranty repairer should be presented with a properly filled in warranty certificate and a receipt of the purchase.



In case the owner or holder of the appliance can't present a valid warranty the repair will not be made as warranty repair. Warranty period service will be made within a reasonable time period and during normal working hours. If it is required for a technician to arrive immediately and outside normal working hours, it may cause additional costs that the client is obliged to pay to the service center that made the repairs.

SERVICE IN FINLAND

The service of this product during the warranty period and thereafter is the responsibility of a nation wide service network, which offers the best product knowledge, flexible service, and advantages of a large spare part storage.

For possible failures during bank holiday periods we recommend taking an additional insurance.

SERVICE CALLS IN FINLAND

Service of products manufactured by Suomen Kotikylmiö Oy in Finland is done by

Festivo Service Tel. (03) 553 8681
huolto@festivo.fi

A service call to that number by a client of Suomen Kotikylmiö Oy will be connected to a service center closest to the client.

Warranty conditions

The warranty period of our domestic appliances is two years starting from the purchase or delivery date. The warranty includes repairs reported to an authorized service center within the warranty period and confirmed by the warranty provider to faults due to structural, manufacturing and raw material failures and damages caused by those to the actual appliance free of charge. The service center will repair the above mentioned faults and making the appliance to operational.

For the cooling system main components (compressor, evaporator and condenser) we will grant a 5 year spare part warranty when the appliance is repaired by a service center authorized by Suomen Kotikylmiö Oy. The spare part warranty covers the cost of the broken component but not the changing or other indirect costs caused by it.

Note!

In case the appliance will be used for another purpose than normal domestic use the warranty should be agreed upon separately and in writing with the manufacturer.

The warranty does not include faults that have been caused by

- transport
- user negligence
- appliance overload
- failure to follow the operating manual or neglecting maintenance
- voltage variation (allowed +/-10%)
- thunderstorm
- Maintenance, repairs and structural changes by other than authorized service centers
- repairs to faults that do not contribute to the functioning of the appliance e.g. surface scratches
- parts, that are more prone to break due to improper handling or normal wear and tear e.g. plastic parts that touched by hand

Decommissioning the appliance

Note!

It is not allowed to deposit the decommissioned appliance to a landfill because it contains e-waste. The appliance has to be disposed according to the amendment to the Waste Act on 13.8.2005 as e-waste.

By the government decree on 9.9.2004 the consumers can return all e-waste (waste electrical and Electric equipment) free of charge to the collection organized by the producers.

Collection points in Finland: www.jly.fi

Warning!

When you dispose of your old cooling appliance be aware of the cooling system pipes. Pipes are not allowed to break because then the cooling system refrigerant and compressor oil can leak into nature. The refrigerant released from the pipes can cause injury to eyes.

Notes

Notes

Notes

FESTIVO

Suomen Kotikylmiö Oy is part of the Finnish Festivo-Porkka Group. All Festivo products are manufactured in Hollola, where Suomen Kotikylmiö Oy's factory, product development, administration, exhibition space and factory's own service and spare parts service are located.

Festivo is a genuine Finnish Key Flag product. The Festivo logo on the front panel of your refrigerator is, therefore, a promise of Finnish quality that is generated by decades of experience, strong materials and the structures and solutions found to work over time.

Suomen Kotikylmiö Oy

Ravitie 3, FIN-15860 Hollola

Tel. +358 (0)10 201 9200

festivo@festivo.fi

Festivo Service

Ravitie 3, FIN-15860 Hollola

Tel. +358 3 553 8681

service@festivo.fi