

Installation and operation manual

CITYCOLD



Rev 072023



FESTIVO

Contents

Intended use	4
Models	4
Reception	4
Before using the appliance	5
Precautions	5
Installation	6
Buttons on the control panel and indicator lights on the display screen	8
Switching on	9
Switching off	10
Review of temperature setting values	10
Temperature control: C refrigerator drawer	11
Temperature control: F freezer drawer	11
Automatic defrosting	11
Additional manual defrosting	11
Interior light	11
Storing foodstuffs	12
Cleaning	13
Normal sounds of the appliance	14
Malfunctions and repairing small faults	15
Service	17
Warranty conditions in Finland	18
Disposal of the equipment	18
Notes	19



Intended use

Citycold cold frost is a drawer device, located underneath the worktop or independent unit, which is suitable for both cold storage and freezing storage. The equipment is intended for use in households. The use of the plant must take into account the regulations of the sector.

Festivo refrigeration equipment has been designed and tested in accordance with current regulations and regulations.

Festivo refrigerator may only be serviced by an authorized service company. Unqualified repairs can be a danger to the user or environment of the device.



Models

The Citycold refrigerator-freezer is available in two models, 600 CF and 800 CF. The appliance includes both a refrigerator temperature (C) and a freezer temperature (F). The refrigerator-freezer contains two drawers, the top one for foods requiring cold storage and the bottom one for frozen products. The top drawer also has an inner drawer for small packages.

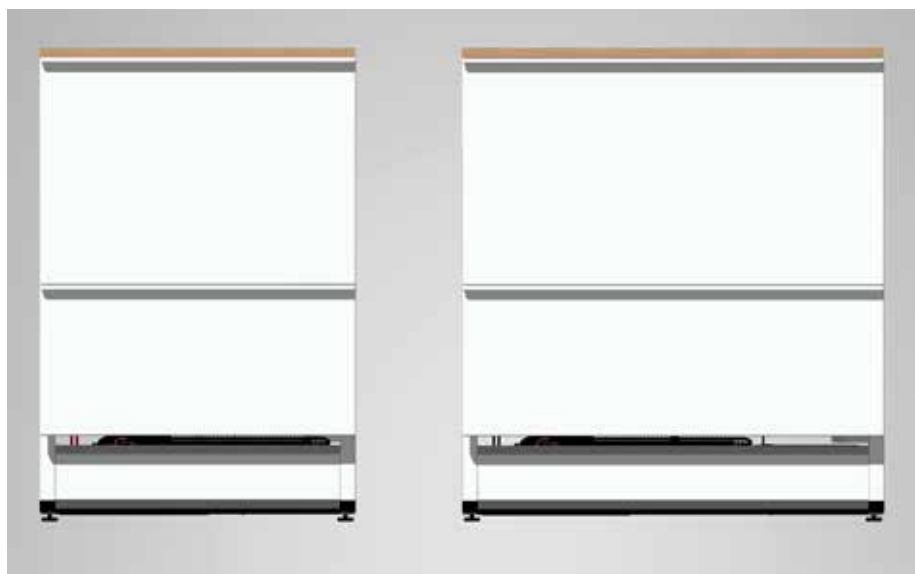

Citycold 600 CF

Citycold 800 CF

Refrigerator temperature (C) +4...+8°C

Freezer temperature (F) -18...-20°C

Reception

Examine the product carefully as soon as you receive it. If you notice that it has suffered from damages during transportation, you must indicate this in the delivery document and report to the carrier and the retailer.

Note!

The manufacturer's guarantee does not cover damages caused by transportation!

Before using the appliance

Read the installation and operating manual carefully. It includes important information about the installation, use and maintenance of the appliance.

Do not start to use the appliance immediately after transportation or after it has been kept in a cold place, but let it stand in its final location for a few hours so that the oil has time to flow down into the compressor.

Precautions

Before cleaning, turn off the appliance from the power switch and unplug it from the socket.

Leave the drawers open when the appliance is not in use.

Alcoholic substances and conserves containing alcohol e.g. gherkins, pickled beetroot and lingonberry puree must be stored upright in a tightly sealed container.

Do not store opened sparkling wine bottles in a drawer, because the motion of opening the door can loosen the bottle cork at a high pressure and it can cause damage with its trajectory.

Do not store glass bottles with freezing liquids in the freezer. The bottle can break.

Do not store explosive substances in the appliance.

Warning!

It is not allowed to install the appliance in a space that is too small because of possible leakage of refrigerant forming an explosive mixture of gas. The room size should be at least 8 m².



The unit contains a small quantity environment friendly but flammable refrigerant, R600a, which does not damage the ozone layer or cause the greenhouse effect. Check the refrigerant piping for damages in transit or during installation. Leaking refrigerant can injure eyes or ignite.

When noticing a refrigerant leakage:

- do not let open fire into the room
- turn off power to the appliance from the main switch
- unplug the appliance from the socket
- air the room for several minutes
- contact the Festivo service center

Note!

Keep the air circulation vents free of obstacles both up and down.

Do not use mechanical tools to speed up melting the ice or other than recommended methods by the manufacturer.

Do not damage the refrigerant piping.

Do not use any electrical equipment inside the refrigerator-freezer unless they are recommended by the manufacturer.

Installation

INSTALLATION LOCATION

The intended environmental temperature classification has been indicated on the appliance nameplate. The rating plate is located on the right-hand interior wall of the top compartment.

SN	+10 ... +32 °C
N	+16 ... +32 °C
ST	+18 ... +32 °C
T	+18 ... +43 °C



Place the appliance in a dry and properly ventilated room with a size of at least 8 m².

Do not place the appliance in the immediate proximity of a radiator, stove, or another heat source.

Note!

Do not cover the condenser air circulation in front of the unit. The device sucks in air from the right edge of the plinth board's air intake opening and removes it from the left edge.

Note!

Manufacturer's warranty does not cover damages that are caused by faulty installation. Check that the cooling air circulation meets at least the instruction requirement.

The placement floor must be even, horizontal, and at the same level with the finished floor.

The frost that is formed in the refrigerator evaporator will be defrosted automatically by the appliance. The defrosting water is led to an evaporating pan in the compressor space. Water evaporates from the evaporation vessel automatically.

In the case of a malfunction of the unit some water can be spilled onto the floor.

We recommend installing a protective basin, which is available at Festivo service.

Alternatively, the location of the appliance can be made watertight in other ways. A watertight base will be raised up onto the wall so that the possible leakage water cannot enter the structure via the floor or wall joints.

The refrigerator-freezer can be placed against the back and side surfaces. In case the appliance's side surface is next to another cooling unit or outer wall, a ventilation gap of 1 cm width should be left in between the surfaces.

Other furniture should not be fastened to the refrigerator-freezer as it should be possible to pull it out for cleaning and maintenance.

Adjust the appliance directly using the adjustment feet so that all adjustment feet touch the floor.



ENSURING AIR CIRCULATION IN THE APPLIANCE PLINTH

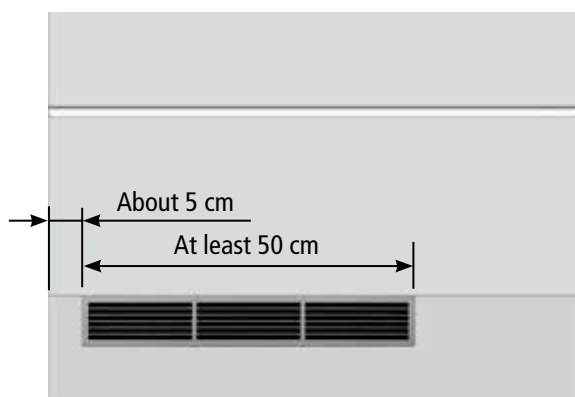

Plinth vent installed in the kitchen plinth

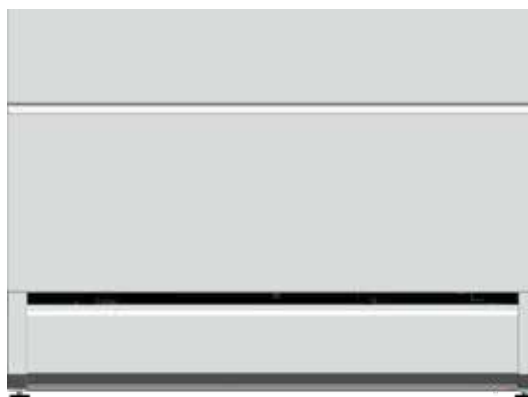

Festivo appliance vent installed

Ensure sufficient condensing air circulation if the Festivo appliance vent is replaced with a separate plinth vent.

I install a separate plinth vent on the upper left edge of the kitchen plinth, so that the air circulation is as unobstructed as possible.

Note!

The total area of the air holes in the plinth vent must be at least 200 cm².

ATTACHING THE INDEPENDENT DEVICE TO THE WALL

Note!

The independent device must always be attached to the wall, a fixed worktop or an adjacent piece of furniture.

Adjust the device to the desired height in a horizontal position. Attach the angle iron (A) to the wall at the height required by the device.

Push the device under the angle iron and fasten it at the back corners with two 4.2x16 sheet metal screws (B).

Install the cover (C) in place so that the protrusions of the fixing iron on the rear edge of the cover go through the holes (D) in the angle iron of the frame.

Finally, screw the cover on its front edge with three 4.2x13 screws.

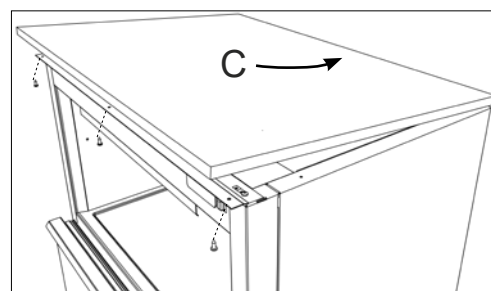
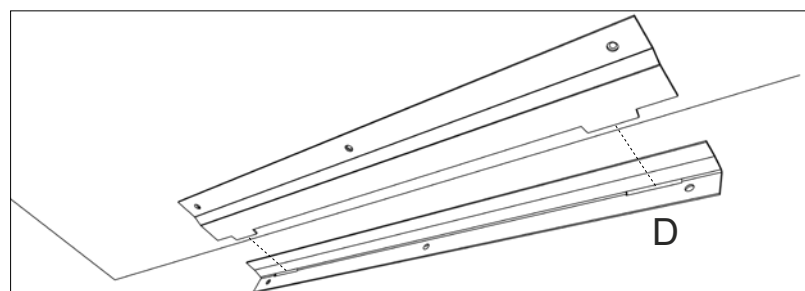
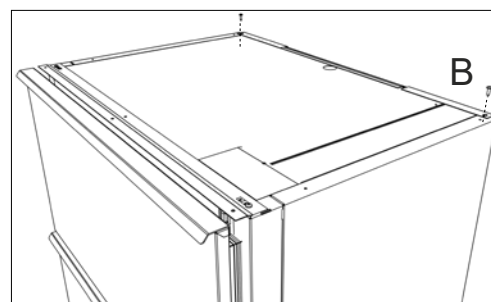
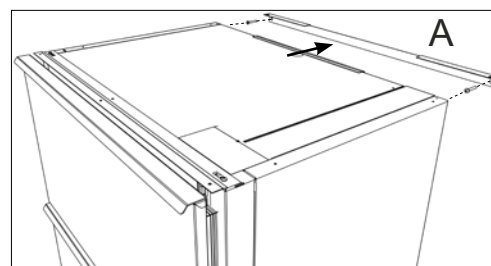

ATTACHING THE DEVICE TO THE BOTTOM SURFACE OF THE TABLE TOP OR TO AN ADJACENT FURNITURE



The device comes with mounting angles for the front edge. Attach the device with a screw from both upper corners to the underside of the work surface or to the adjacent piece of furniture.

ADJUSTING AND FIXING THE FRONT PLATE OF THE DRAWERS



PICTURE 1

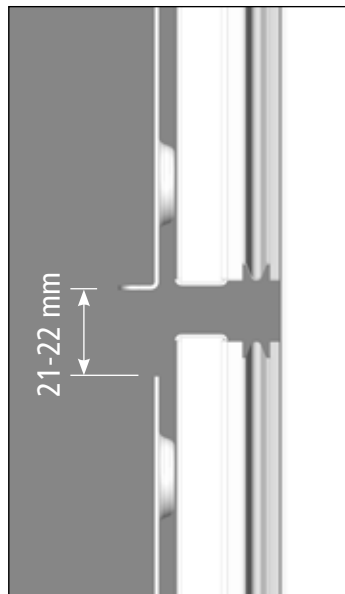

PICTURE 2

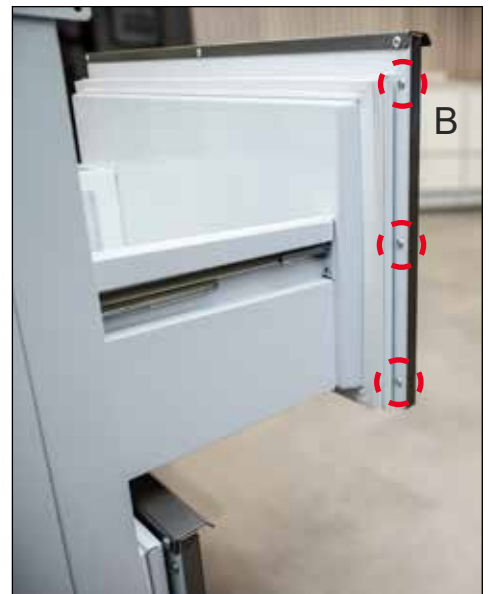

PICTURE 3



PICTURE 4

The drawers have screw-fastened (5 pcs) finely adjustable mounting plates (PICTURE 1). Loosen the M4 Torx fixing screws A of the mounting plate (PHOTO 4) and adjust the plates horizontally.

Leave a gap of at least 21 mm between the mounting plates of the model to be integrated into the kitchen cabinet (PHOTO 2).

After fine-tuning the mounting plates, fasten the wooden front plates from the mounting holes B of the adjustment plate (PHOTO 3) with the supplied Wronic 4.2x16 low head screws (6 pcs. upper drawer and 4 pcs. lower drawer). Drill about 10 mm deep pilot holes for the screws. If necessary, use the dimensioning picture (PICTURE 5) as help.

Note!

If the front plate is thinner than 20 mm, make sure that the screw does not puncture the outer surface of the front plate. If necessary, use a shorter screw.

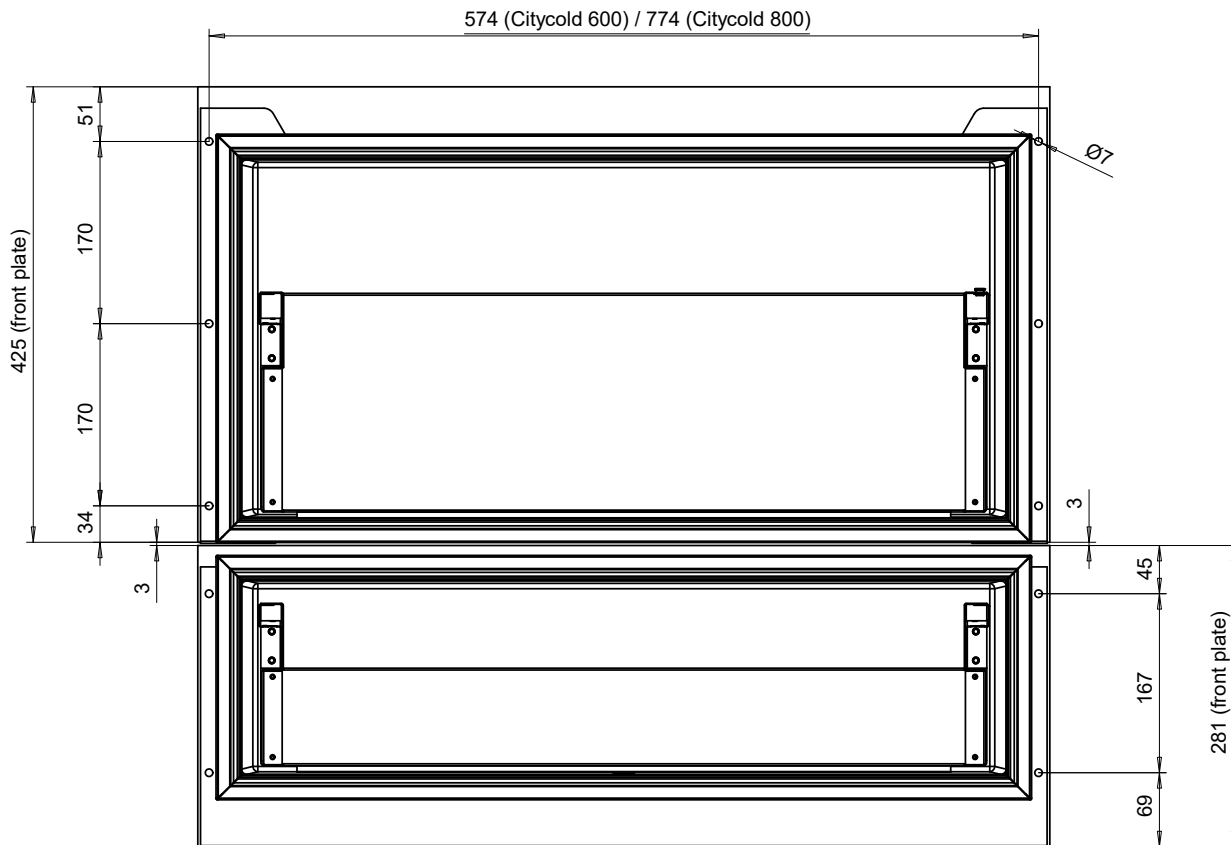

PICTURE 5

APPLIANCE PROTECTIVE BASIN

Note!

Always install a protective basin under the appliance.



Alternatively, the location of the appliance can be made watertight in other ways. A watertight base will be raised up onto the wall so that the possible leakage water cannot enter the structure via the floor or wall joints.

POWER CONNECTION

Connect the refrigerator-freezer power cord to a single-phase 230 V 50 Hz socket. The fuse size of the socket is 10 A.

Only an electrician may make changes to the connection method or change the connection lead.

Note!

The socket must be positioned in such a way that it is possible to pull the appliance's plug from the socket without having to move the appliance.





Due to danger of overheating the appliance should not be connected to the power grid by means of a branch outlet or an extension cord.

Buttons on the control panel and indicator lights on the display screen









The control panel has an operating terminal and a main power switch. At the bottom of the terminal, there are four buttons for various functions. The display has two separate display lines for top and bottom drawer functions.



BUTTONS

Button	Short press	Long press (4 seconds)
	Main power switch. Turns on or off the power of the whole device.	
	The light switch is not in use. Exit button for the parameter programming menu.	The stand-by switch of the device, 'stand-by'. In OFF mode, the appliance's refrigeration circuit is off, but features such as the lights are on. In ON mode, the appliance operates normally.
	Browsing adjustable parameters. Decreases the value of the selected parameter.	
	Browsing adjustable parameters. Increases the value of the selected parameter.	Starts an additional defrosting process.
	Displays the value set on the temperature controller. Save button in the parameter programming menu.	

INDICATOR LIGHTS ON THE DISPLAY SCREEN

On the screen	The indicator light is on	The indicator light is flashing
	The operating terminal is in OFF mode.	The indicator light flashes briefly when the operating terminal is switched on or off by pressing its own power button  .
	Displays the temperature of the C refrigerator drawer. Displays the value of the parameter to adjust in the programming mode.	
	Displays the temperature of the F freezer drawer. Displays the value of the parameter to adjust in the programming mode.	
	The defrosting function is running.	The drying cycle is on (F freezer drawer only).
	The compressor is running.	The compressor is waiting for the end of the start-up delay.
	The evaporator fan is running.	The evaporator fan is not running.
	The appliance sounds an alarm, but the user has seen and acknowledged the alarm.	The appliance sounds an alarm, but the alarm has not yet been seen and acknowledged by the user.

Switching on

Do not start to use the appliance immediately after transportation or after it has been kept in a cold place, but let it stand in its final location for a few hours so that the oil has time to flow down into the compressor.

Before using the appliance, clean its interior parts (see the chapter on 'Cleaning').

Push the plug on the connecting lead of the appliance into the electric socket.

Do not place food into the appliance before the drawer temperatures have reached their set values.

At the factory, the main switch of the appliance  was left in the OFF position.

Push the main switch, and within 10 seconds, the interior temperature of the refrigerator will appear on the display.

Inside temperatures of the appliance can be monitored from the controller display.

Switching off

Switch off the appliance using the main switch .

The appliance refrigeration circuit can be switched off separately. Push the display main switch  until the display turns off.

Review of temperature setting values



RECOMMENDED FACTORY SET TEMPERATURE VALUES:

C refrigerator drawer +5 °C, the temperature may be set to +4...+8 °C

F freezer drawer -18 °C, the temperature may be set to -18...-20 °C

The key lock is automatically activated if the buttons on the screen are not touched for 30 seconds. The text 'Loc' is displayed for 4 seconds, and the key lock is active.

Press the button  for 4 seconds to display the text 'UnL' and open the keypad lock.

Press the button  again to display the set temperature value for the **C refrigerator drawer**.



Press the button , to display the set temperature value for the **F freezer drawer**.



Temperature control: C refrigerator drawer

When the controller is in the temperature set value review phase for the refrigerator drawer, press **SET**, and the set value will start flashing, and you can adjust the temperature by pressing **∇ AUX** and **∧**.

Press the button **SET** to confirm the change. Press **⏻** or wait approximately 10 seconds for the controller to return to normal mode.

Temperature control: F freezer drawer

When the controller is in the temperature set value review phase for the freezer drawer, press **SET**, and the set value will start flashing, and you can adjust the temperature by pressing **∇ AUX** and **∧**.

Press the button **⏻**, to end the operation, and the controller will return to normal mode.

Automatic defrosting

Both the refrigerator and the freezer drawer have an automatic defrosting function which may be switched on as required.

C refrigerator drawer:

During defrosting, the text 'DEF' appears on the display and the temperature of the refrigerator drawer may temporarily rise slightly. The temperature returns to the set value when defrosting is complete.

F freezer drawer:

During defrosting, the text 'dEF' appears on the display, and the temperature may temporarily rise slightly.

Additional manual defrosting

Press the button **∧** for 4 seconds to start the additional defrosting function.

Note!

If the freezer drawer is warmer than its set value, the appliance will only defrost the refrigerator drawer vaporiser (displayed as 'dEF' on the screen).

If the defrosting of the freezer drawer starts (displayed as 'dEF'), the defrosting of the refrigerator drawer will also be launched (displayed as 'dEF').



The appliance automatically returns to normal mode after a post-defrosting delay.

Interior light

The interior light of both the refrigerator and the freezer drawer will turn on automatically when you open the drawer. The light will turn off within 20 seconds after closing the drawer. The light button **⏻** on the controller is not active.

Storing foodstuffs

Note!

There is a fan behind both the refrigerator and freezer drawers on the rear interior wall. Please ensure the unobstructed operation of fans.

C REFRIGERATOR DRAWER AND INNER DRAWER +4...+8 °C

The internal temperature of the refrigerator drawer has been set at the factory to +5 °C. The temperature differs slightly from the set value to layout value in various parts of the drawer.

Note!

In damp weather, water may condense on inner surfaces. Increasing the C refrigerator drawer temperature by a few degrees may reduce condensation.

Package or cover the foods if possible. When packaged the food taste, humidity and freshness will keep the best and other foods will not take on other tastes.

Juices and preserves can also be stored in the refrigeration box for long periods of time. Foodstuffs for day-to-day use will normally keep for a few days.

The coldest storage compartment of the C refrigerator drawer is the inner drawer, making it ideal for storing e.g. dairy products (butter, cream, yoghurt). We do not recommend storing fruit and vegetables in the inner drawer.

There is space for tall containers such as bottles on the right-hand side of the refrigerator drawer.

F FREEZER DRAWER -18...-20 °C

The internal temperature of the freezer drawer has been set at the factory to -18 °C. The temperature differs slightly from the set value to layout value in various parts of the drawer.

Note!

Warm products must not be placed in the freezer. Instead, they must be pre-cooled in a refrigerated drawer before freezing.

The quality of frozen foods deteriorates if the maximum storage period is exceeded. The storage period depends on the type of food.



Cleaning

CLEANING THE REFRIGERATOR AND FREEZER DRAWERS

The insides of the refrigerator-freezer should be cleaned and defrosted approximately once every six months.

Turn off the main power switch  for cleaning. Where necessary, store food supplies in another cold storage space.

Note!

The main power switch switches off both the refrigerator and the freezer drawer.

Remove the bottom plates of both drawers to facilitate cleaning. For instance, you can place a towel on the bottom of the freezer drawer to absorb any water dripping down the walls.

Note!

Do not allow cleaning water to penetrate the controls or LED lights.

Where necessary, protect the floor from splashing water and wait until all the ice has melted.



Note!

It's not allowed to use e.g. a knife or hot air blower to remove the ice.

You can clean all inner surfaces except for the drawer seal with warm water, adding a small amount of dish washing liquid. Abrasive or dissolving agents are not suitable for cleaning. Clean the drawer seal with water only. Carefully dry the interior and the seal and leave the drawer open for a while for ventilation.

Start the appliance after cleaning. Press the button . The appliance will switch on and the display indicates the temperature inside the refrigerator-freezer. The engine runs until the inside temperature has reached its inside set-point.

Note!

Leave the drawers open when the appliance is not in use.

CLEANING THE CONDENSER

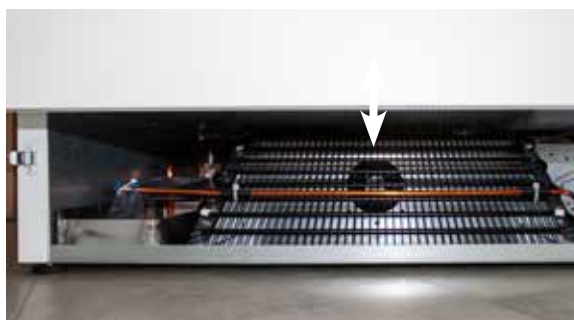

Remove the socle plate by pulling the ends of the plate straight forward. Carefully vacuum the condenser, for example with a vacuum cleaner brush nozzle, in the direction of the thin wires.

Normal sounds of the appliance

The appliance uses the compressor-operated refrigeration system for cooling. The system makes sounds of varying levels and they can increase especially during the defrosting phase. The volume of the noise is also affected i.e. by the materials in the environment where it is placed (e.g. stone floors), the manner of positioning the appliance, the way it is used and its age.

Resonance noise may be produced if the appliance is not completely straight, or if parts of the pipe system are touching one another. The pipes can be bent apart carefully by hand.

During the operation of the appliance, sounds may be heard due to the different thermal expansion of metal parts of various sizes.

REFRIGERATION SYSTEM

When the refrigerant flows through the pipelines one may hear hissing or bubbling noises. During the defrosting phase a cracking sound can be heard.

THERMOSTAT

The compressor is started and stopped by a thermostat. When the thermostat switches on, it makes a low cracking sound. The compressor is required to run more frequently if the doors are opened more often.

COMPRESSOR

When the refrigerant is being pumped, a droning or "snoring" noise is heard from the compressor motor and the pump.

Malfunctions and repairing small faults

All malfunctions do not necessarily need to be solved with the help of a technician. Thus, you should first check whether you can clear the problem by following the instructions below. If the appliance does not have a fault you will have to cover the cost of the service call even during the warranty period.

If the refrigerator engine does function, check the following:

- you have followed the operating manual instructions
- the plug is plugged properly into the socket
- the fuse is intact
- the main switch and power switches are in the 'on' position
- there are no disturbances in the power distribution

Note!

If the environment temperature becomes unusually high the compressor safety device can stop the engine. Restarting can take ½ - 1 h depending on the circumstances.

If the cooling capacity is poor:

- Please check that the drawers are closed tightly.
- The doors have been opened often and kept open for too long
- too many products have been placed to cool at the same time
- air circulation is blocked either outside or inside
- check that the evaporators haven't gathered thick ice on them

Note!

Thick ice in the refrigerator vaporisers should be defrosted by switching off the refrigerator until the ice has melted completely. When defrosting large amounts it should be ensured that the evaporator dishes at the appliance base will not overflow onto the floor.

Refrigerator-freezer LED lights:

The appliance has LED lighting with a long life cycle. In the event of a failure please contact Festivo service.

The F freezer drawer indicates overheating (AHF). Check first if:

- The freezer has been filled with too many products to freeze without freezer function

Freezing goods temporarily rises the temperature inside the freezer, which may trigger the temperature alarm. This is not a fault in the appliance and the alarm will disappear as the freezing continues.

- The freezer drawer has been left open. Switch on the additional defrosting function (where necessary, 2 times in succession). If the appliance capacity remains low even after this and the temperature is still high after 24 h of defrosting, please contact the Festivo service.

Alarms

ALARMS, C-REFRIGERATOR DRAWER

PrC = interior sensor failure

The refrigerator follows the set program despite a sensor failure. However, the temperature can sometimes vary. The fault must be repaired. Please contact Festivo service.

AHC = High temperature alarm

Please see first chapter 'Malfunctions'. Please contact the Festivo service in case the above mentioned points are in good order and the appliance does not begin to cool within two hours.



ERROR MESSAGES, F FREEZER DRAWER

PrF = sensor failure

The freezer works despite the sensor fault with the set program. However, the temperature can sometimes vary. The fault must be repaired. Please contact Festivo service.

AHF = High temperature alarm

Please see first chapter 'Malfunctions'. In case the above mentioned points are in good order and the appliance temperature does not return to normal within approximately two hours, please contact Festivo service.

Service

If you can't remove the appliance malfunction, call the help of a technician. Do not try to repair the appliance by yourself, especially not its electrical parts.

Unnecessary opening of the drawers will raise the temperature inside the appliance.

Warranty repairs can be done only by a service centers that are authorized by the factory.

Note!

When you order a warranty repair for the appliance please provide the unit warranty information:

- serial number and exact type number of the appliance. This information is available on the rating plate on the right interior wall of the refrigerator.
- Appliance purchase and delivery date.

Note!

The warranty repairer should be presented with a properly filled in warranty certificate and a receipt of the purchase.

In case the owner or holder of the appliance can't present a valid warranty the repair will not be made as warranty repair. Warranty period service will be made within a reasonable time period and during normal working hours. If it is required for a technician to arrive immediately and outside normal working hours, it may cause additional costs that the client is obliged to pay to the service center that made the repairs.

SERVICE IN FINLAND

The service of this product during the warranty period and thereafter is the responsibility of a nation wide service network, which offers the best product knowledge, flexible service, and advantages of a large spare part storage.

For possible failures during bank holiday periods we recommend taking an additional insurance.

SERVICE CALLS IN FINLAND

Service of products manufactured by Suomen Kotikylmiö Oy in Finland is done by

Festivo Service Tel. (03) 553 8681
huolto@festivo.fi

A service call to that number by a client of Suomen Kotikylmiö Oy will be connected to a service center closest to the client.

Warranty conditions

The export sales warranty period for the raw material and components is one (1) years if not agreed otherwise. The warranty applies to the equipment sold to the first buyer, i.e. goods have left the factory. The warranty does not cover wear and conditions caused by normal use or the batteries of the appliance.

The warranty includes repairs reported to an authorized service center within the warranty period and confirmed by the warranty provider to faults due to structural, manufacturing and raw material failures and damages caused by those to the actual appliance free of charge. The service center will repair the above mentioned faults and making the appliance to operational.

Note!

In case the appliance will be used for another purpose than normal domestic use the warranty should be agreed upon separately and in writing with the manufacturer.

The warranty does not include faults that have been caused by

- transport
- user negligence
- appliance overload
- failure to follow the operating manual or neglecting maintenance
- voltage variation (allowed +/-10%)
- thunderstorm
- Maintenance, repairs and structural changes by other than authorized service centers
- repairs to faults that do not contribute to the functioning of the appliance e.g. surface scratches
- parts, that are more prone to break due to improper handling or normal wear and tear e.g. plastic parts that touched by hand

Disposal of the equipment

Note!

Once the equipment becomes redundant it must not be disposed of with normal waste because the equipment is governed by the WEEE directive. It has to be disposed of following the WEEE act which became effective on August 13th 2005.

Warning!

When you dispose of your old cooling appliance be aware of the cooling system pipes. Pipes are not allowed to break because then the cooling system refrigerant and compressor oil can leak into nature. The refrigerant released from the pipes can cause injury to eyes.

FESTIVO

Suomen Kotikylmiö Oy is part of the Finnish Festivo-Porkka Group. All Festivo products are manufactured in Hollola, where Suomen Kotikylmiö Oy's factory, product development, administration, exhibition space and factory's own service and spare parts service are located.

Festivo is a genuine Finnish Key Flag product. The Festivo logo on the front panel of your refrigerator is, therefore, a promise of Finnish quality that is generated by decades of experience, strong materials and the structures and solutions found to work over time.

Suomen Kotikylmiö Oy

Ravitie 3, FIN-15860 Hollola

Tel. +358 (0)10 201 9200

festivo@festivo.fi

Festivo Service

Keskikankaantie 17, FIN-15860 Hollola

Tel. +358 (0)3 553 8681

huolto@festivo.fi